

CU 80 E



CU 80

- Foto delle macchine conformi alle norme CE
- Abgebildete Modellen in EG-Ausführung
- Pictures of the machines in CE version
- Photos des machine conformes aux norms CE
- Fotos de las maquinás conforme normas CE

• Le misure ed i pesi sono approssimativi. La Ditta si riserva di apportare miglione e modifiche senza alcun preavviso. • Abmessungen und Gewichte können ohne vorherige Ankündigung geändert werden. • Weight and dimensions of machines, as well as performances, can be changed or modified at any time without notice.
 • Les dimensions et les poids sont approximatifs. La Maison peut apporter des modifications sans aucun préavis. • Las Medidas y pesos son aproximados. La empresa se reserva el derecho de modificaciones sin previo aviso.



DATI TECNICI	CU 80E	CU 80
Lunghezza tavola mm	560	580
Larghezza tavola mm	250	300
Lunghezza massima della cava mm	250	250
Profondità massima della cava mm	160	160
Corsa verticale mm	200	200
Mandrino portapunte ø mm	0÷16	0÷20
Giri mandrino g/min	3000	3000
Potenza motore HP/KW	3 (2,2)	3 (2,2)
Peso netto Kg	180	230



TECHNISCHE DATEN	CU 80E	CU 80
Tischlänge mm	560	580
Tischbreite mm	250	300
Bohrlänge mm	250	250
Bohrtiefe mm	160	160
Höhenverstellung mm	200	200
Bohrfutter ø mm	0÷16	0÷20
Bohrdrehzahl U/min	3000	3000
Motorleistug PS/KW	3 (2,2)	3 (2,2)
Nettogewicht	180	230



TECHNICAL DATA	CU 80E	CU 80
Length of the table mm	560	580
Width of the table mm	250	300
Maximum slot width mm	250	250
Maximum slot depth mm	160	160
Vertical stroke mm	200	200
Mortising chuck ø mm	0÷16	0÷20
Rotation speed mortising chuck r.p.m.	3000	3000
Motor power HP/KW	3 (2,2)	3 (2,2)
Net weight Kg	180	230



DONNÉE TECHNIQUES	CU 80E	CU 80
Longueur de la table mm	560	580
Largeur de la table mm	250	300
Longueur maxi de la mortaiseuse mm	250	250
Profondeur maxi de la mortaiseuse mm	160	160
Course verticale mm	200	200
Mandrino porte - meche ø mm	0÷16	0÷20
Tours du mandrin porta - meche	3000	3000
Puissance moteur CV/KW	3 (2,2)	3 (2,2)
Poids net Kg	180	230



DATOS TECNICOS	CU 80E	CU 80
Longitud de la mesa mm	560	580
Anchura de la mesa mm	250	300
Longitud max de la ranura mm	250	250
Profundidad max de la ranura mm	160	160
Recorrido vertical mm	200	200
Portabrocas para puntas ø mm	0÷16	0÷20
R.P.M. motor	3000	3000
Potencia motor HP/KW	3 (2,2)	3 (2,2)
Peso neto Kg	180	230

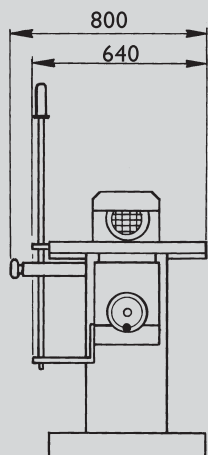
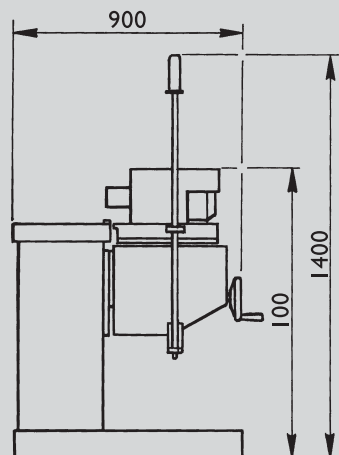

• A RICHIESTA • ZUBEHÖR • OPTIONALS •
 • OPTIONS • PRINCIPALES OPCIONALES •

- Inclinazione gruppo portamandrino + 45° 0 -45°
- Bohrfutterschrägstellung + 45° 0 -45°
- Tilting mortising unit + 45° 0 -45°
- Inclinaison groupe porte mandrin + 45° 0 -45°
- Inclinación del grupo portabrocas +45° 0 -45°

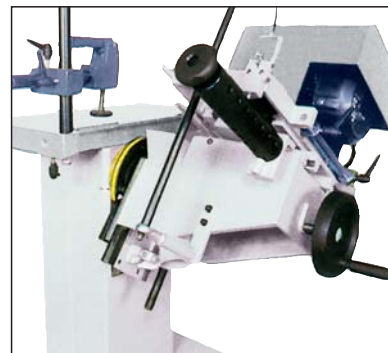

- Tamburo a 4 passi
- 4 Stellungen - Trommel
- 4 pitches - drum
- Tambour à 4 voies
- Tambor de 4 pasajes

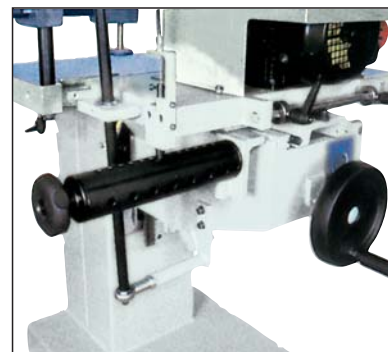

- Pressore pneumatico
- Lunftpresse
- Pneumatic pressing
- Presseur pneumatique
- Prensor neumatico

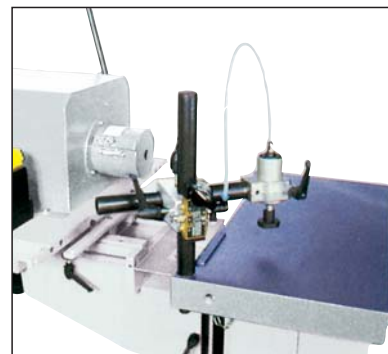

- Squadretto sul piano
- Gehrungsanschlag am Tisch
- Mitre fence on the table
- Guide à onglet sur la table
- Escuadra sobre la mesa



- Ruotina per trasporto manuale con timone
- Fahreinrichtung mit Steuer
- Small wheels for manual transport with shaft
- Petites roues pour transport manuel avec timon
- Ruedas para el transporte manual con timón